

# FIBER LASER MARKING MACHINE BML-FC SERIES

## LASERMEISTER



**LASERPINKIDE MÜÜK; KOMPONENDID; HOOLDUS**

*Pakume teile erinevaid laserpinkide lahendusi täitmaks teie soove alates pinkide müügist kuni ostujärgse nõustamise ja hoolduseni*



# PARTS AND FUNCTION



Smaller volume  
Smaller volume  
more portable.

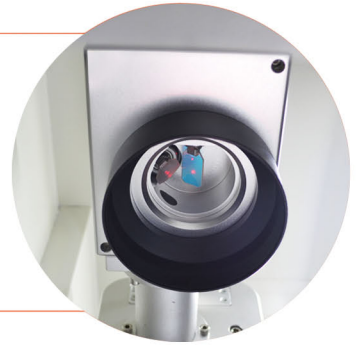

Scanning  
galvanometer  
Germany SCANLAB  
galvanometer

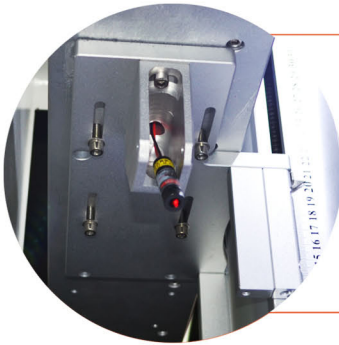

Easy-focusing device  
Easy-focusing device,  
Bodor's patented design



Marking big  
format materials  
Widely use on more  
materials.

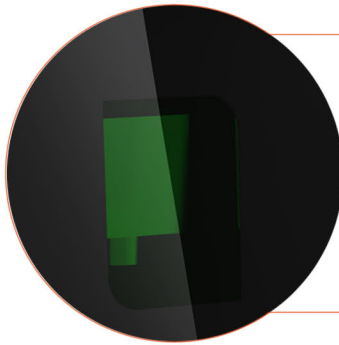

Laser protective glass  
Protecting eyes,  
anti-radiation,  
dustproof function.

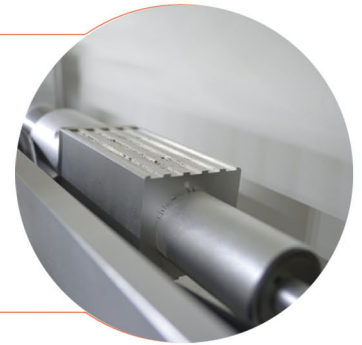

Aluminum alloy  
fastenings  
Nice shape design,  
durable in use



LED light  
Energy efficiency  
High brightness  
Long life time



The working platforms  
can be lifted  
Second table could be up and down.  
First table used on 100mm lens,  
it could be moved on other lens.

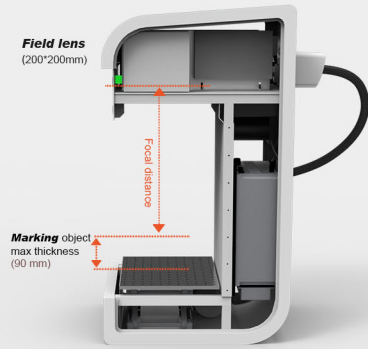
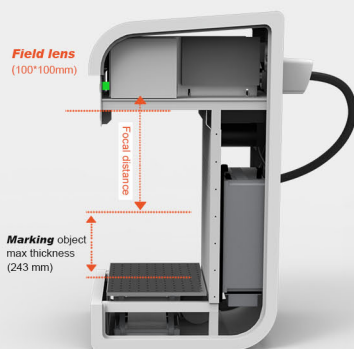
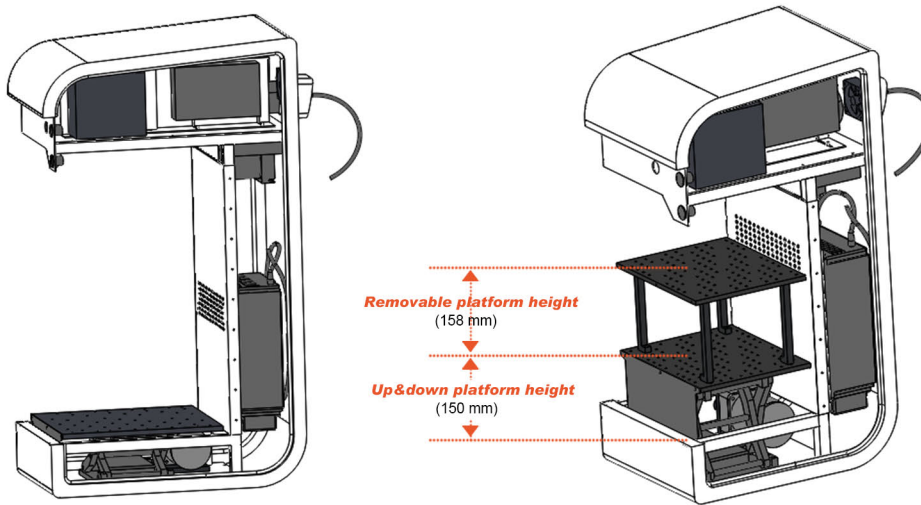

# PRODUCT INTRODUCTION

**1**

High speed marking

Special laser head for high-speed scanning

**2**

High quality laser beam.  
Fine marking!

The diameter of focal spot is not over 20 um

**3**

Long lifetime

More than 100000 hours life for the laser source

**4**

Low consumption

About 0.5kw for whole machine

**5**

Safe

Protective cover with anti radiation function, dustproof and eyes protecting

**6**

Portable

Easy to carry

MACHINE PARAMETER

Model	BML20FC	BML30FC
Working Area	100*100mm(Option: 200*200mm)	
Laser Power	20W	30w
Frenquency	20KHz~30KHz	20KHz~80KHz
Frequency	1064nm	
Minimum Line Width	0.02mm	
Minimum Characte	0.15mm*0.15mm	
Engraving Line Speed	≤ 7000mm/s	
Repeatability Accuracy	±0.01mm	
Graphic Format Supprted	bmp . jpg . gif . tga . png . tif . ai . dxf . dst . plt .etc	
Unit Power	< 0.5km	
Laser Module Life	> 100000 hours	

SAMPLES SHOW

